

GEARTOOTH SPEED SENSOR

GS1005 – GS1007 Series



Hall-effect geartooth speed sensor with adjustable aluminum housing.

Features

- Senses motion of ferrous geartooth targets
- Near zero speed sensing capability
- Immune to rotational alignment
- 10 bit dynamic threshold detection offers
 - Automatically adjusting magnetic range
 - Self compensating to target geometry
 - Immune to target run out
- Compatible with unregulated power supply
- Reverse battery protected to -24VDC
- Meets IEC529 IP67 for dust and water protection
- Discrete wire version: 20 AWG, tin plated, polyolefin insulation

- Connector version: M12 integral connector meets IEC 60947-5-2 for low voltage devices
- Hard coat anodized aluminum housing

Applications

- Exercise equipment
- Food processing equipment
- Speedometer

Specifications

Part Number	Operating Voltage Range (VDC)	Supply Current (mA max.)	Output	Output Saturation Voltage (mV max.)	Output Current (mA max.)	Operating Temp Range (°C)	Storage Temp Range (°C)	Thread	Barrel Length	Leads	Connector
GS100501	4.5 – 24	6	sink	400	25	-40 to 105	-40 to 105	M12-1	65mm	—	12mm circular
GS100502	4.5 – 24	6	sink	400	25	-40 to 125	-40 to 125	M12-1	65mm	20 AWG x 1m BBB	—
GS100701	4.5 – 24	6	sink	400	25	-40 to 125	-40 to 125	15/32" – 32	1.00"	20 AWG x 1m BBB	—

Notes: These sensors require the use of an external pull-up resistor, the value of which is dependent on the supply voltage. See page 18 for recommendations. Pull-up resistor should be connected between output (Black) and Vcc (Brown).

Dimensions inches (mm)

All tolerances ± 0.005 (0.13) unless otherwise noted.

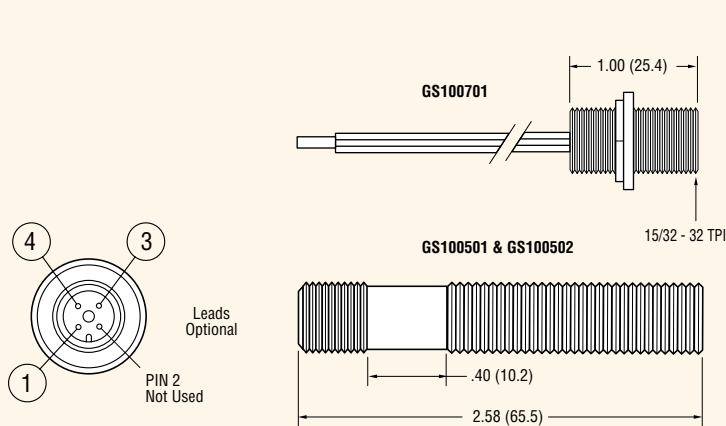

Open Collector Sinking Block Diagram

